

# BigSimulator (BigNetSim) for Extremely Large Parallel Machines

The Charm++ BigSim Emulator was developed by Arun Singla, Neelam Saboo and Joshua Unger under the guidance of Prof. L. V. Kale. The new Converse BigSim Emulator was completely rewritten by Gengbin Zheng. The Converse BigSim Emulator is the only version under maintenance now. Charm++ and Adaptive MPI (AMPI) were ported onto the BigSim Emulator by Gengbin Zheng. The parallel performance simulator was developed by Gengbin Zheng and Gunavardhan Kakulapati. A postmortem network simulator was developed by Terry Wilmarth, Eric Bohm and Gengbin Zheng

---

University of Illinois  
CHARM++/CONVERSE Parallel Programming System Software  
Non-Exclusive, Non-Commercial Use License

Upon execution of this Agreement by the party identified below ("Licensee"), The Board of Trustees of the University of Illinois ("Illinois"), on behalf of The Parallel Programming Laboratory ("PPL") in the Department of Computer Science, will provide the CHARM++/CONVERSE Parallel Programming System software ("CHARM++") in Binary Code and/or Source Code form ("Software") to Licensee, subject to the following terms and conditions. For purposes of this Agreement, Binary Code is the compiled code, which is ready to run on Licensee's computer. Source code consists of a set of files which contain the actual program commands that are compiled to form the Binary Code.

1. The Software is intellectual property owned by Illinois, and all right, title and interest, including copyright, remain with Illinois. Illinois grants, and Licensee hereby accepts, a restricted, non-exclusive, non-transferable license to use the Software for academic, research and internal business purposes only, e.g. not for commercial use (see Clause 7 below), without a fee.
2. Licensee may, at its own expense, create and freely distribute complimentary works that interoperate with the Software, directing others to the PPL server (<http://charm.cs.uiuc.edu>) to license and obtain the Software itself. Licensee may, at its own expense, modify the Software to make derivative works. Except as explicitly provided below, this License shall apply to any derivative work as it does to the original Software distributed by Illinois. Any derivative work should be clearly marked and renamed to notify users that it is a modified version and not the original Software distributed by Illinois. Licensee agrees to reproduce the copyright notice and other proprietary markings on any derivative work and to include in the documentation of such work the acknowledgement:

"This software includes code developed by the Parallel Programming Laboratory in the Department of Computer Science at the University of Illinois at Urbana-Champaign."

Licensee may redistribute without restriction works with up to 1/2 of their non-comment source code derived from at most 1/10 of the non-comment source code developed by Illinois and contained in the Software, provided that the above directions for notice and acknowledgement are observed. Any other distribution of the Software or any derivative work requires a separate license with Illinois. Licensee may contact Illinois ([kale@cs.uiuc.edu](mailto:kale@cs.uiuc.edu)) to negotiate an appropriate license for such distribution.

3. Except as expressly set forth in this Agreement, THIS SOFTWARE IS PROVIDED "AS IS" AND ILLINOIS MAKES NO REPRESENTATIONS AND EXTENDS NO WARRANTIES OF ANY KIND, EITHER EXPRESS OR IMPLIED, INCLUDING BUT NOT LIMITED TO WARRANTIES OR MERCHANTABILITY OR FITNESS FOR A PARTICULAR PURPOSE, OR THAT THE USE OF THE SOFTWARE WILL NOT INFRINGE ANY PATENT, TRADEMARK, OR OTHER RIGHTS. LICENSEE ASSUMES THE ENTIRE RISK AS TO THE RESULTS AND PERFORMANCE OF THE SOFTWARE AND/OR ASSOCIATED MATERIALS. LICENSEE AGREES THAT UNIVERSITY SHALL NOT BE HELD LIABLE FOR ANY DIRECT, INDIRECT, CONSEQUENTIAL, OR INCIDENTAL DAMAGES WITH RESPECT TO ANY CLAIM BY LICENSEE OR ANY THIRD PARTY ON ACCOUNT OF OR ARISING FROM THIS AGREEMENT OR USE OF THE SOFTWARE AND/OR ASSOCIATED MATERIALS.
4. Licensee understands the Software is proprietary to Illinois. Licensee agrees to take all reasonable steps to insure that the Software is protected and secured from unauthorized disclosure, use, or release and will treat it with at least the same level of care as Licensee would use to protect and secure its own proprietary computer programs and/or information, but using no less than a reasonable standard of care. Licensee agrees to provide the Software only to any other person or entity who has registered with Illinois. If licensee is not registering as an individual but as an institution or corporation each member of the institution or corporation who has access to or uses Software must agree to and abide by the terms of this license. If Licensee becomes aware of any unauthorized licensing, copying or use of the Software, Licensee shall promptly notify Illinois in writing. Licensee expressly agrees to use the Software only in the manner and for the specific uses authorized in this Agreement.
5. By using or copying this Software, Licensee agrees to abide by the copyright law and all other applicable laws of the U.S. including, but not limited to, export control laws and the terms of this license. Illinois shall have the right to terminate this license immediately by written notice upon Licensee's breach of, or non-compliance with, any terms of the license. Licensee may be held legally responsible for any copyright infringement that is caused or encouraged by its failure to abide by the terms of this license. Upon termination, Licensee agrees to destroy all copies of the Software in its possession and to verify such destruction in writing.
6. The user agrees that any reports or published results obtained with the Software will acknowledge its use by the appropriate citation as follows:

"CHARM++/CONVERSE was developed by the Parallel Programming Laboratory in the Department of Computer Science at the University of Illinois at Urbana-Champaign."

Any published work which utilizes CHARM++ shall include the following reference:

"L. V. Kale and S. Krishnan. CHARM++: Parallel Programming with Message-Driven Objects. In 'Parallel Programming using C++' (Eds. Gregory V. Wilson and Paul Lu), pp 175-213, MIT Press, 1996."

Any published work which utilizes CONVERSE shall include the following reference:

"L. V. Kale, Milind Bhandarkar, Narain Jagathesan, Sanjeev Krishnan and Joshua Yelon. CONVERSE: An Interoperable Framework for Parallel Programming. Proceedings of the 10th International Parallel Processing Symposium, pp 212-217, April 1996."

Electronic documents will include a direct link to the official CHARM++ page at <http://charm.cs.uiuc.edu/>

7. Commercial use of the Software, or derivative works based thereon, REQUIRES A COMMERCIAL LICENSE. Should Licensee wish to make commercial use of the Software, Licensee will contact Illinois ([kale@cs.uiuc.edu](mailto:kale@cs.uiuc.edu)) to negotiate an appropriate license for such use. Commercial use includes:
  - (a) integration of all or part of the Software into a product for sale, lease or license by or on behalf of Licensee to third parties, or
  - (b) distribution of the Software to third parties that need it to commercialize product sold or licensed by or on behalf of Licensee.
8. Government Rights. Because substantial governmental funds have been used in the development of CHARM++/CONVERSE, any possession, use or sublicense of the Software by or to the United States government shall be subject to such required restrictions.
9. CHARM++/CONVERSE is being distributed as a research and teaching tool and as such, PPL encourages contributions from users of the code that might, at Illinois' sole discretion, be used or incorporated to make the basic operating framework of the Software a more stable, flexible, and/or useful product. Licensees who contribute their code to become an internal portion of the Software agree that such code may be distributed by Illinois under the terms of this License and may be required to sign an "Agreement Regarding Contributory Code for CHARM++/CONVERSE Software" before Illinois can accept it (contact [kale@cs.uiuc.edu](mailto:kale@cs.uiuc.edu) for a copy).

UNDERSTOOD AND AGREED.

Contact Information:

The best contact path for licensing issues is by e-mail to [kale@cs.uiuc.edu](mailto:kale@cs.uiuc.edu) or send correspondence to:

Prof. L. V. Kale  
Dept. of Computer Science  
University of Illinois  
201 N. Goodwin Ave  
Urbana, Illinois 61801 USA  
FAX: (217) 333-3501

# Contents

|          |   |          |
|----------|---|----------|
| <b>1</b> | <b>BigSim Network Simulator</b>                           | <b>3</b> |
| 1.1      | What does this software do? . . . . .                     | 3        |
| 1.2      | Compiling BigSimulator . . . . .                          | 3        |
| 1.3      | Using BigSimulator . . . . .                              | 3        |
| 1.3.1    | Simple Latency Model . . . . .                            | 4        |
| 1.3.2    | Artificial Traffic Models . . . . .                       | 4        |
| 1.4      | Which Interconnection networks are implemented? . . . . . | 5        |
| 1.5      | Build your own Interconnection network . . . . .          | 5        |
| 1.6      | BigNetSim Design and Internals . . . . .                  | 5        |
| 1.7      | Topology, Routing and Virtual Channel Selection . . . . . | 6        |
| 1.7.1    | Topology . . . . .  | 6        |
| 1.7.2    | Routing . . . . .   | 7        |
| 1.7.3    | Input Virtual Channel Selection . . . . .                 | 7        |
| 1.7.4    | Output Virtual Channel Selection . . . . .                | 7        |

# 1 BigSim Network Simulator

The BigSim Network Simulator is also known as Bigsimulator and lives in the SVN repository <https://charm.cs.uiuc.edu/svn/r>. The Network simulator is actually more of an Inter-connection network simulator and hence more important in the context of large parallel machines with interconnects. The BigSim simulator along with the network simulator is together also known as BigNetSim.

Both the simulators run on top of the POSE framework, which is a Parallel Discrete Event Simulation framework built on top of CHARM++.

## 1.1 What does this software do?

BigNetSim is an effort to simulate large current and future computer systems to study the behavior of applications developed for those systems. BigNetSim could be used to study

- new types of interconnection topologies and routing algorithms along with different types of switching architecture.
- application performance on different machines. This uses the API provided in Section ?? to run the application on some number of processors on some machine and generate (dump) all events (entry method executions or message send/recv). BigNetSim is used to model the machine that needs to be studied for this application and these logs are then fed into this simulation, and it predicts the performance of this application.

So, the two important uses are studying *interconnection networks* and *performance prediction for applications*.

## 1.2 Compiling BigSimulator

To compile the simulator which is called BigSimulator (or BigNetSim), we need the regular Charm++ build (net-linux-x86\_64 in our example). It needs to be complemented with a few more libraries from BigSim and with the Pose discrete-event simulator. These pieces can be built, respectively, with:

```
./build bgampi net-linux-x86_64 -O2
./build pose net-linux-x86_64 -O2
```

Access to the discrete-event simulation is realized via a Charm++ package originally named BigNetSim (now called BigSimulator). Assuming that the 'subversion' (svn) package is available, this package can be obtained from the Web with a subversion checkout such as:

```
svn co https://charm.cs.uiuc.edu/svn/repos/BigNetSim/
```

In the subdir 'trunk/' created by the checkout, the file Makefile.common must be edited so that 'CHARM-BASE' points to the regular Charm++ installation. Having that done, one chooses a topology in that subdir (e.g. BlueGene for a torus topology) by doing a "cd" into the corresponding directory (e.g. 'cd BlueGene'). Inside that directory, one should simply "make". This will produce the binary "../tmp/bigsimulator". That file, together with file "BlueGene/netconfig.vc", will be used during a simulation. It may be useful to set the variable SEQUENTIAL to 1 in Makefile.common to build a sequential (non-parallel) version of bigsimulator.

## 1.3 Using BigSimulator

BigSimulator (BigNetSim) has 2 major modes.

- Trace based traffic simulation
- Artificial traffic generation based simulation. The mode of the simulator is governed by the *USE\_TRANSCEIVER* parameter in the netconfig file. When set to 0, trace based simulation is used, when set to 1, traffic generation is used.

Trace based simulation. This is used to study target application performance, or detailed network performance when loaded by a specific application.

There are two command line parameters for traced based simulation.

```
./charmrun +p2 ./bigsimulator arg1 arg2
```

arg1 = 0 => Latency only mode

1 => Detailed contention model

arg2 = N => starts execution at the time marked by skip point N (0 is start)

### 1.3.1 Simple Latency Model

To use the simple latency model, follow the setup procedure above, noting that the files are located in the trunk/SimpleLatency directory. This will produce the "bigsimulator" file.

The command line parameters used for this model are different. The format is as follows:

```
[charmrun +p#] bigsimulator -lat <latency> -bw <bandwidth>
                [-cpp <cost per packet> -psize <packet size>]
                [-winsize <window size>] [-skip] [-print_params]
```

Latency (lat) - type double; in microseconds  
Bandwidth (bw) - type double; in GB/s  
Cost per packet (cpp) - type double; in microseconds  
Packet size (psize) - type int; in bytes  
Window size (winsize) - type int; in log entries

The implemented equation is:  $lat + (N/bw) + cpp \times (N/psize)$

Latency and bandwidth are required. If cost per packet is given, then packet size must be given, as well. Otherwise, cost per packet defaults to 0.0. Packet size, if given, must be a positive integer.

The -winsize flag allows the user to specify the size of the window (number of log entries) used when reading in the bgTrace log files. This is useful if the log files are large. If -winsize is not specified, the value defaults to 0, which indicates that no windowing will be used (i.e., there will be one window for each time line that is equal to the size of the time line).

As with the second parameter in the examples of part (a) of this section, the -skip flag indicates that the simulation should skip forward to the time stamp set during trace creation (see the BigSim tutorial talk from the 2008 Charm++ workshop). If -skip is not included, then no skipping will occur.

The -print\_params flag is provided for debugging convenience. When present, the simple latency model parameters will be displayed during simulation initialization.

### 1.3.2 Artificial Traffic Models

Artificial traffic generation based simulation is use to study the performance of interconnects under standard network load schemes.

```
./bigsimulator arg1 arg2 arg3 arg4 arg5 arg6
```

example

```
./bigsimulator 1 2 3 100 2031 0.1
```

arg1 = 0 => Latency only mode

1 => Detailed contention model

arg2 = 1 => deterministic traffic

2 => poisson traffic

arg3 = 1 => KSHIFT

2 => RING

```
3 => BITTRANSDPOSE
4 => BITREVERSAL
5 => BITCOMPLEMENT
6 => UNIFORM_DISTRIBUTION
arg4 = number of packets
arg5 = message size
arg6 = load factor
```

## 1.4 Which Interconnection networks are implemented?

A large number of topologies and routing strategies are implemented in the software. Here, we present a list of interconnection networks. For a complete list of routing strategies, input/output VC selectors, refer to the corresponding directories in the software.

- HyperCube
- FatTree
- DenseGraph
- Three dimensional Mesh
- K-ary-N-cube
- K-ary-N-fly
- K-ary-N-mesh
- K-ary-N-tree
- N-mesh
- Hybrid of Fattree and Dense Graph
- Hybrid of Fattree and HyperCube

## 1.5 Build your own Interconnection network

To build a new interconnection network, one has to create a new directory for that interconnection network and then create the routing strategy, topology, input virtual channel selection and output virtual channel selection strategies for that network. If existing strategies could be used, then reuse them, but if new ones are required, one has to write these new strategies in the corresponding directories for routing, topology, etc.

The `InitNetwork` function must be provided in `InitNetwork.C` for this new interconnection network. It builds up all the nodes and switches and NICs and channels that form the network. Look at one of the existing interconnection topologies for reference.

## 1.6 BigNetSim Design and Internals

This section focuses on the interconnection network simulation. The entities that form an interconnection network are:

- *switch*: A switch decides the routing on a packet. Switches could be input buffered or output buffered. The former are implemented as individual posers per port of each switch while the latter are implemented as a poser per switch. In an *Input Buffered (IB)* switch, a packet in a switch is stored at the input port until its next route is decided and leaves the switch if it finds available space on the next switch in the route. While in an *Output Buffered (OB)* switch, a packet in a switch decides beforehand on the next route to take and is buffered at the output port until space is available on the next switch along the route. Switches are modeled in much detail. Ports, buffers and virtual channels at ports

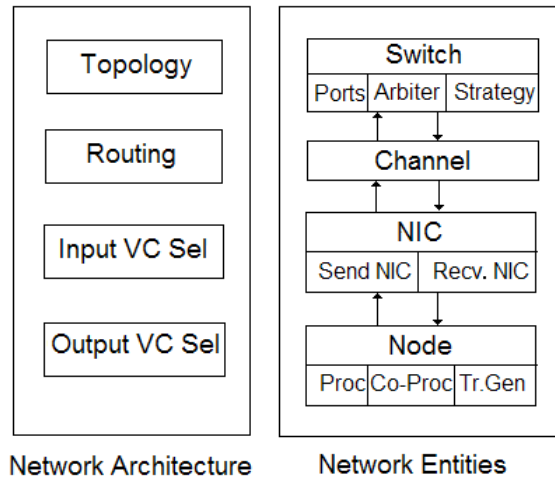

Figure 1: BigNetSim conceptual model

to avoid head-of-the-line blocking are modeled. Hardware collectives are implemented on the switch to enable broadcasts, multicasts and other collective operations efficiently. These are configurable and can be used if the system being simulated supports them. We also support configurable strategies for arbitration, input virtual channel selection and output virtual channel selection. The configurability of the switch provides a flexible design, satisfying the requirements of a large number of networks.

- *network card*: Network cards packetize and unpacketize messages. A NIC is implemented as two posers. The sending and receiving entities in a NIC are implemented as separate posers. A NIC is attached to each node.
- *channel*: These are modeled as posers and connect a NIC to a switch or a switch to another switch.
- *compute node*: Each compute node connects to a network interface card. A compute node simulates execution of entry methods on it. It is also attached to a message traffic generator, which is used when only an interconnection network is being simulated. This traffic generator can generate any message pattern on each of the compute nodes. The traffic generator can send point-to-point messages, reductions, multicasts, broadcasts and other collective traffic. It supports k-shift, ring, bit-transpose, bit-reversal, bit-complement and uniform random traffic. These are based on common communication patterns found in real applications. The frequency of message generation is determined by a uniform or Poisson distribution.

## 1.7 Topology, Routing and Virtual Channel Selection

Topology, Routing strategies and input and output virtual channel selection strategies need to be decided for any inter-connection network. Once we have all of these in place we can simulate an inter-connection network.

### 1.7.1 Topology

For every architecture one wants to design, a topology file has to be written which defines a few basic functions for that particular topology. These are:

```
void getNeighbours(int nodeid, int numP);
```

This is called initially for every switch and this populates the data structure *next* in a switch which contains the connectivity of that switch. The switch specified by *switch* has *numP* ports.

int getNext(int portid, int nodeid, int numP)

Returns the index of the switch/node that is connected to the switch *nodeid*, at *portid*. The number of ports this node has is *numP*.

int getNextChannel(int portid, int nodeid, int numP)

Returns the index of the channel that is connected to the switch *nodeid*, at *portid*. The number of ports this node has is *numP*.

int getStartPort(int nodeid, int numP, int dest)

Return the index of the port that is connected to this compute node from a switch

int getStartVc()

Returns the index of the first virtual channel (mostly 0).

int getStartSwitch(int nodeid)

Returns the index of the node/switch that is connected to the first port

int getStartNode()

Returns the index of the first node. Each poser has a separate index, irrespective of the type of the poser.

int getEndNode()

Returns the index of the last node.

### 1.7.2 Routing

Routing strategy needs to be specified for every interconnection network. There is usually at least one routing strategy that needs to be defined for every topology, Usually we have many more. The following functions need to be defined for every routing strategy.

int selectRoute(int current, int dest, int numP, Topology\* top, Packet \*p, map<int,int> &bufsize, unsigned short \*xsubi)

Returns the portid that should be taken on switch *current* if the destination is *dest*. The number of ports on a switch is *numP*. We also pass the pointer to the topology and to the Packet.

int selectRoute(int current, int dest, int numP, Topology\* top, Packet \*p, map<int,int> &bufsize, map<int,int> &portContention, unsigned short \*xsubi)

Returns the portid that should be taken on switch *current* if the destination is *dest*. The number of ports on a switch is *numP*. We also pass the pointer to the topology and to the Packet. *Bufsize* is the state of the ports in a switch, i.e. how many buffers on each port are full, while *portContention* is used to give priority to certain ports, when more options are available.

int expectedTime(int src, int dest, POSE\_TimeType ovt, POSE\_TimeType origOvt, int length, int \*numHops)

Returns the expected time for a packet to travel from *src* to *dest*, when the number of hops it will need to travel is *numHops*.

int convertOutputToInputPort(int id, Packet \*p, int numP, int \*next)

Translate this output port to input port on the switch this port is connected to.

### 1.7.3 Input Virtual Channel Selection

For every switch, we need to know the mechanism it uses to choose input virtual channel. There are a few different input virtual channel selection strategies, and a switch can choose among them. Each should implement the following function.

int selectInputVc(map<int,int> &availBuffer, map<int,int> &request, map<int,vector<Header<int>>> &inBuffer, int globalVc, int curSwitch)

Returns the input virtual channel to be used depending on the strategy and the input parameters.

### 1.7.4 Output Virtual Channel Selection

For every switch, we need to know the mechanism it uses to choose output virtual channel. There are a few different output virtual channel selection strategies, and a switch can choose among them. Each should implement the following function.

int selectOutputVc(map<int,int> &bufsize, Packet \*p, int unused)

Returns the output virtual channel to be used depending on the strategy and the input parameters.